

DFC Series

In-line Deflagration Flame Arresters



Protecting People, Property and our Planet

With Replaceable Element for Explosion Gas Groups IIB & IIC.

The Elmac Technologies® DFC Series of In-line Deflagration Flame Arresters are designed to prevent propagation of flames in gas or vapour mixtures. By locating the arrester in close proximity to the potential source of ignition, any flame or explosion is confined to the immediate area. DFC Arresters are supplied as complete units ready for direct installation into piping systems. In the context of the Pressure Equipment Directive (PED), Elmac Flame Arresters are classified as a piping assembly.

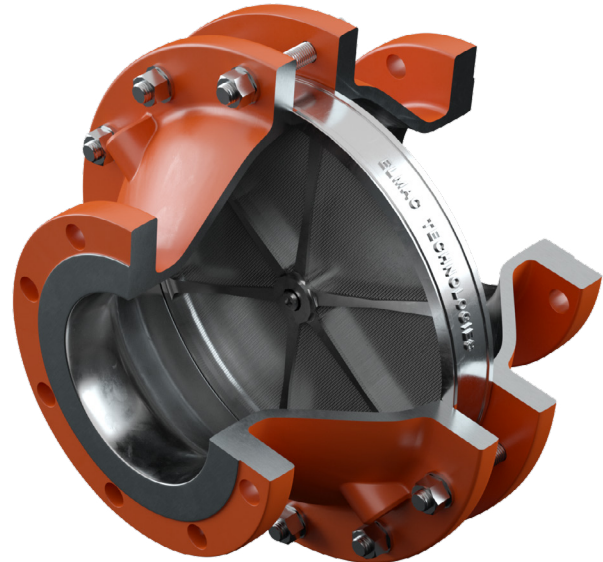

Principle of Operation

A flame arrester uses an element with small apertures which allows gas or vapour to pass. If the apertures are smaller than the maximum experimental safe gap (MESG) for the gas or vapour then a flame cannot pass through the arrester, and is subsequently contained or extinguished.

Explosion Gas Groups

Elmac In-line Deflagration Flame Arresters in the DFC Series are for use with gases in Explosion Groups IIB and IIC.

Standards Compliance

All Elmac Deflagration Flame Arresters have been tested and certified in accordance with national or international standards.

Actual device performance is verified in the Elmac Technologies® state-of-the-art in-house test facility.



Elmac Expertise

Elmac have been manufacturing protection equipment since 1948 and bring enhanced levels of flame and explosion protection to a diverse range of applications.

Elmac offers considerable technical leadership and, using test facilities along with Computational Fluid Dynamics capabilities, employs research teams renowned for developing solutions for the most challenging of industrial applications.

Features and Benefits

- Variety of sizes and materials to suit a wide range of applications
- Replaceable elements
- Bi-directional
- The Elmac technical team can advise on specific location queries

General Arrangements:

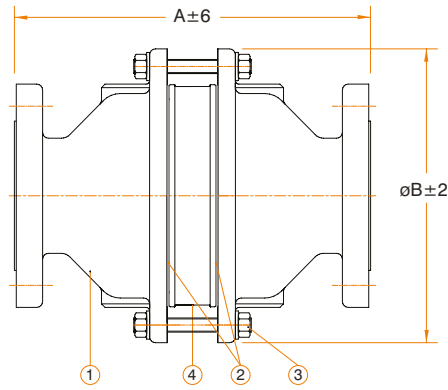

Material Specifications

Ref	Description	Carbon Steel	Stainless Steel
1	Body	Carbon Steel	Stainless Steel
2	Gaskets	Klingersil C4400	Klingersil C4400
3	Fasteners	Carbon Steel	Stainless Steel
4	Element – Housing	Carbon Steel	Stainless Steel
4	Element – Core	Stainless Steel	Stainless Steel

NB (mm)	25	40	50	80	100	150
Ø Element (mm)	137	137	137	189	237	339
A (mm)	213	213	243	303	313	363
Ø B (mm)	185	185	185	250	310	430

Operating Limits*

NB (mm)	25	40	50	80	100*	150
Temperature (°C)	60	60	60	60	60	60
Pressure (bara)	1.10	1.10	1.10	1.10	1.10, 1.45	1.20
Pipe Length / Diameter Ratio (L/D)	30	30	30	10	10, 10	10

*100mm NB arrester has 1.10bara or 1.45bara options with different pressure drop characteristics.

Customer Support

Tel: +44 (0) 1352 717 555

Email: sales@elmactech.com

Fax: +44 (0) 1352 717 642

Coast Road, Greenfield, Flintshire, CH8 9DP United Kingdom



Protecting People, Property and our Planet