

EVB Series

End-of-line Deflagration Flame Arresters



Protecting People, Property and our Planet

With Replaceable Element for Explosion Gas Groups IIB1, IIB2 & IIB3.

The Elmac Technologies® EVB Series End-of-line Deflagration Flame Arresters are designed to be installed at the end of a pipeline or exit vent from a vessel, where the ignition source is external, to provide protection against atmospheric deflagration.

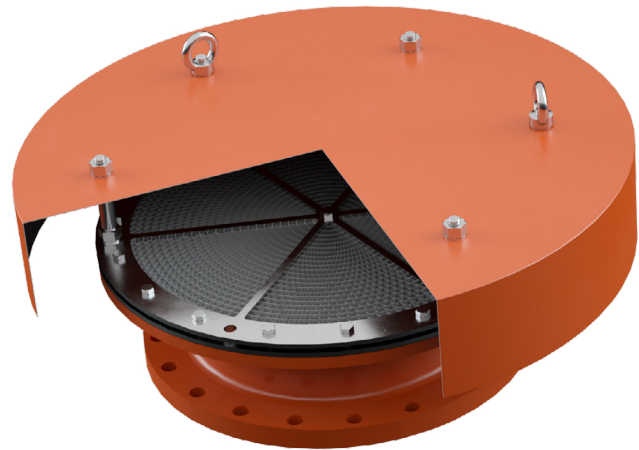

Principle of Operation

The EVB Series incorporates Elmac's E-Flow™ enhanced crimped-ribbon technology in the flame arresting element, the matrix of which has been optimised using CFD to ensure industry leading flow and pressure drop characteristics.

During a deflagration, the combustion products are cooled at the element surface by heat dissipation, which prevents continuation of the combustion process through the arrester and into the protected vent line.

Operating Conditions

Elmac EVB End-of-line Deflagration Flame Arresters are ATEX certified for a maximum operating temperature of +60°C

Explosion Gas Groups

Elmac EVB Series End-of-line Deflagration Flame Arresters are ATEX approved for gases in Explosion Gas Groups IIA, IIA1, IIB1, IIB2, & IIB3.

Standards Compliance

EVB End-of-line Deflagration Flame Arresters have been type-tested to EN ISO 16852 and approved according to ATEX Directive 94/9/EC.

Actual device performance is verified in the Elmac Technologies® state-of-the-art in-house test facility.



Elmac Expertise

Elmac have been manufacturing protection equipment since 1948 and bring enhanced levels of flame and explosion protection to a diverse range of applications.

Elmac offers considerable technical leadership and, using test facilities along with Computational Fluid Dynamics capabilities, employs research teams renowned for developing solutions for the most challenging of industrial applications.

Features and Benefits

- Exceptional flow capacities with minimal pressure drop
- Easy-clean, replaceable, crimped-ribbon elements
- Unique element design is less susceptible to fouling/clogging
- Sizes and materials to suit a wide range of applications
- End connections include flanged or threaded options
- Lightweight for ease of installation
- Bird screen fitted as standard

General Arrangements:

EVB Flame Arresters: DN 15-40mm

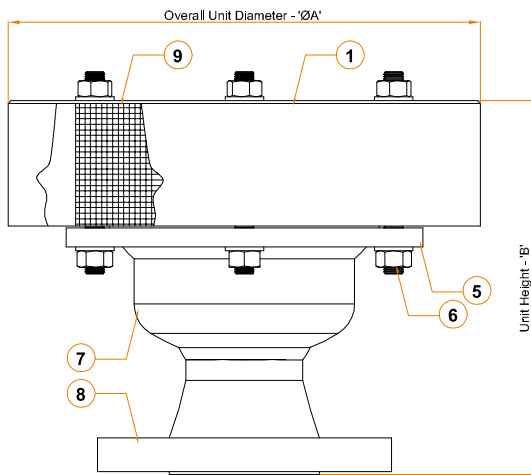

EVB Flame Arresters: DN 50-600mm

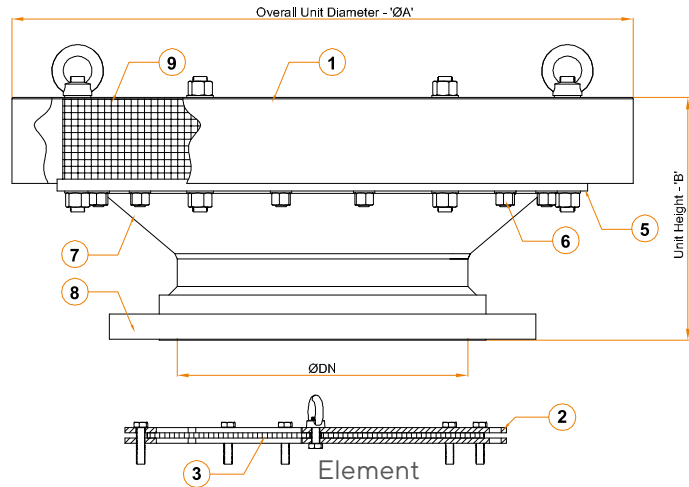

Standard Material Specifications

Ref	Description	Carbon Steel Models	Stainless Steel Models
1	Weatherhood	316 Stainless Steel	316 Stainless Steel
2	Element Housing	Carbon Steel	316 Stainless Steel
3	Element Core	316L Stainless Steel	316L Stainless Steel
4*	Gasket	PTFE	PTFE
5	Element Flange	Carbon Steel	316 Stainless Steel
6	Fasteners	Carbon Steel BZP	316 Stainless Steel
7	Reducer	Carbon Steel	316 Stainless Steel
8	Fixing Flange	Carbon Steel	316 Stainless Steel
9	Bird Screen	316 Stainless Steel	316 Stainless Steel

*Not shown in General arrangement drawings above

Dimensions*

NB (mm)	15	20	25	32	40	50	65	80	100
ØA (mm)	245	245	245	245	245	245	300	300	360
B (mm)	192	197	199	200	205	195	230	230	246
Approx Wt (kg)	7.0	7.2	7.5	7.8	8.2	8.6	14.5	15.2	20.2

NB (mm)	125	150	200	250	300	350	400	450	500	600
ØA (mm)	420	500	500	600	660	790	870	950	1030	1200
B (mm)	279	325	325	492	528	342	350	390	403	461
Approx Wt (kg)	26.5	41.2	46.0	79.6	103.2	113.9	134.9	157.3	182.0	230.0

*Some arresters are available with differently sized elements for enhanced flow capabilities. Please contact Customer Support for details.

Variations

Feature	Standard Fitting	Options*
Arrester Materials	Carbon Steel or Stainless Steel	Low Temperature Carbon Steel, Duplex Steel, Hastelloy
Element Material	316L Stainless Steel	Hastelloy
Connections	ANSI 150 Flange	PN16 Flange, Female BSP/NPT, Male BSP/NPT
Arrester Finish	Painted (Carbon Steel Arresters)	Offshore Paint, PTFE Coated, Others on Request
Bird Screen	316 Stainless Steel	304 Stainless Steel, PTFE Coated

*May be limited according to arrester size

Customer Support

Tel: +44 (0) 1352 717 555

Email: sales@elmactech.com

Fax: +44 (0) 1352 717 642

Coast Road, Greenfield, Flintshire, CH8 9DP United Kingdom



Protecting People, Property and our Planet