

LCA Series

In-line Deflagration Flame Arresters



Protecting People, Property and our Planet

With Replaceable Element for Explosion Gas Groups IIA & IIA1

The LCA Series of In-Line Deflagration Flame Arresters is designed to prevent the propagation of flames in piping systems. Flames (or an explosion) are confined to the immediate area by positioning one of our flame arresters in close proximity to the potential source of ignition.

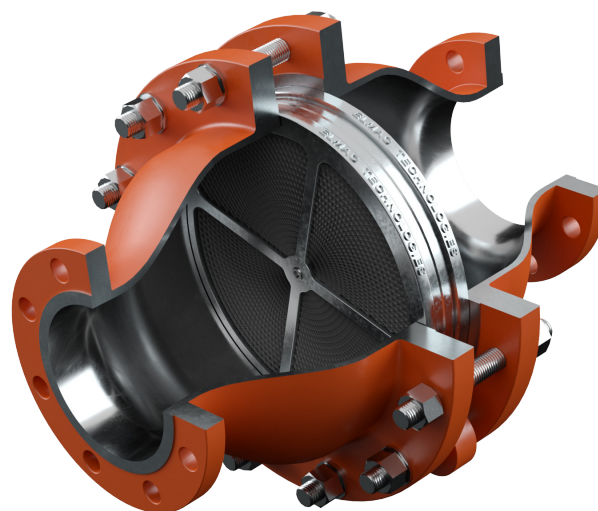

Principle of Operation

LCA flame arresters models include high pressure, high temperature and short-time burning proof variants. For a deflagration with no stabilised flame, the combustion products are cooled at the element surface by heat dissipation. This prevents continuation of the combustion process through the flame arrester and into the protected line.

In the event that a flame stabilises on the flame arrester element, a sudden increase in temperature will be detected by a monitoring system and secondary protection measures are activated to stop the flow of the flammable mixture.

Explosion Gas Groups

Elmac LCA Series Flame Arresters are ATEX certified for Explosion Groups IIA1 and IIA.

Standards Compliance



Elmac's LCA Series of In-line Deflagration Unstable Detonation Flame Arresters has been type-tested to EN ISO 16852 and approved according to ATEX Directive 2014/34/EU.

Elmac Expertise

Elmac has been manufacturing protection equipment since 1948 and brings enhanced levels of flame and explosion protection to a diverse range of applications.

Features and Benefits

The LCA Series incorporates crimped-ribbon technology in the flame arrester element, the metal matrix of which has been optimised utilising our in-house CFD capability to ensure industry-leading flow vs pressure drop characteristics.

- Suitable for in-line deflagration
- ATEX certified for explosion groups IIA1, IIA, IIB1, IIB2, IIB3
- Exceptional flow capacities with minimal pressure drop
- Short-time burning proof capability
- Bi-directional protection
- Elevated operating temperature and pressure models available
- Easy-clean, replaceable, crimped-ribbon elements
- Sizes and materials to suit a wide range of applications
- End connections include flanged or threaded option

LCA Series

In-line Deflagration Flame Arresters

General Arrangements:

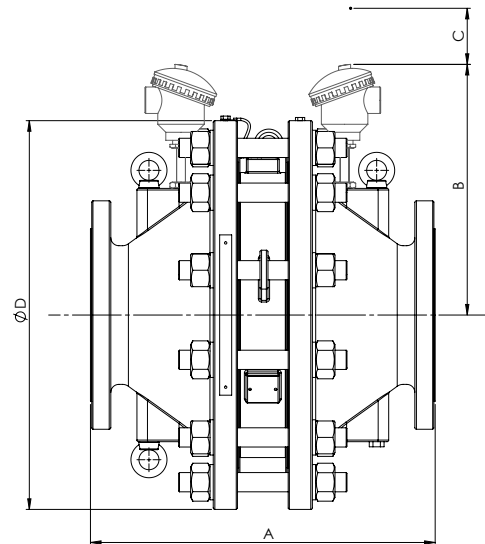

Sizes

Dimensions (mm)	Max Operating Pressure (bara)	Max Operating Temperature (°C)	Connection Size (DN)						
			50	80	100	150	200	250	300
A: Overall length	1.20	60	304	354	360	430	450	480	500
	1.45	160	314	364	370	440	460	490	510
	1.50	60	314	364	370	440	460	490	510
	1.60	60	314	364	370	-	-	-	-
D: Ø Diameter			230	279	345	485	595	700	815
B: Centre to top of temperature probe for short-time burn models (mm)			258	283	304	340	382	430	466
C: Minimum Clearance for short-time burn models (mm)			55	75	75	135	135	185	185
Approx Wt (kg)			28	40	60	116	190	259	366

NOTES

- Weights are given for standard units (short time burn, high temperature and high pressure variants may be different).
- Dimensions B & C may be reduced if the temperature sensor is installed at an angle (45° to top dead centre).

Variations

Features	Standard Fitting	Options*
Arrester Housing Materials	Carbon or Stainless Steel	Low Temperature Carbon Steel, Duplex Steel, Hastelloy
Element Material	Stainless Steel	Hastelloy
Connections	ANSI 150 Flange	PN16 Flange, Female BSP/NPT, Male BSP/NPT
Arrester Finish	Painted (Carbon Steel Arresters)	Offshore Paint, PTFE Coated, Others on Request

*Depending on flame arrester size.

Customer Support

Tel: +44 (0) 1352 717 555

Email: sales@elmactech.com

Fax: +44 (0) 1352 717 642

Coast Road, Greenfield, Flintshire, CH8 9DP United Kingdom



Protecting People, Property and our Planet